

IRB 1200

A compact, flexible, fast and functional small industrial robot



Have you ever wanted to make your machines 15% smaller and 10% faster? ABB's IRB 1200 allows you to do exactly that. Specifically, it addresses the needs of material handling and machine tending applications for flexibility, ease of use, compactness and short cycle times while still maintaining large working envelopes.

The IRB 1200 comes in three variants -7 kg/0.9 m, 7 kg/0.7 m, 5 kg/0.9 m. All IRB 1200 variants can be mounted at any angle and come with IP 40 protection as standard. These variants are available with Food Grade Lubrication, Foundry Plus 2, and Cleanroom options.

Food Grade Lubrication option

This option features food grade lubrication on all axes, wrist flanges, motor covers, and IP67 protection against dust and liquid. NSF H1 food-grade lubrication throughout is designed to meet the constraints of food and beverage applications.

Foundry Plus 2 option

The Foundry Plus 2 option enables the robot to withstand harsh environments and meets the requirements for use in metal die casting, sand casting, forging, and machining applications. The Foundry Plus 2 is IP67 compliant from base to wrist, meaning that the robot's electrical compartments are sealed against liquid and solid contaminants.

Cleanroom option

This option means that the cleanroom robot is sealed, which reduces particle contamination and prevents grease and oil leakage into production areas for products and devices such as electronics, pharma, and lab automation. The cleanroom robot is ISO 14644-1 Class 3 certified, making it ideal for

manufacturing settings requiring exceptional cleanliness and minimal particle emission, all while maintaining top-notch speed and performance.

Compact

The IRB 1200 has no offset in axis two, which results in a longer stroke than other small robots and it, meaning it can be placed very close to the work piece and still be functional. This allows for a much more compact installation when the robot is mounted on the ceiling inside a small cell, such as in electronics machining or polishing applications. The robots' large useable working area contained in a small package leads to shorter cycles and more compact machines.

Features and benefits

- 15% smaller cells that have 10% shorter cycle times
- Available with Food Grade Lubrication
- Optionally with SafeMove functionality
- Available with Foundry Plus 2 protection for harsh environments
- IP40 protection as standard; cleanroom, IP67 and Foundry Plus 2 protection are also available options
- 4 air ducts, 10 customer signals and Ethernet routed internally from wrist flange to foot
- Mountable at any angle
- Large useable working area in a compact footprint

Specification

Robot version	Reach (m)	Payload (kg)	Armload (kg)
IRB 1200-7/0.7	0.7	7	0.3
IRB 1200-5/0.9	0.9	5	0.3
IRB 1200-7/0.9*	0.9	7	0.5
Number of axes	6		
Protection	Standard IP40 Option IP67 and Foundry Plus 2		
Cleanroom	Option ISO class3		
Food Grade Lubricant	Option, only available with IRC5		
Mounting	Any angle		
Controller	OmniCore E10, C30, C90XT, IRC5 Compact/IRC5 Single Cabinet		
Integrated signal and power supply	10 signals on wrist		
Integrated air supply	4 air on wrist (5 Bar)		
Integrated ethernet	One 100/10 Base-TX ethernet port		

*IRB 1200-7/0.9 is only available with OmniCore

Performance (according to ISO 9283)

	IRB 1200-7/0.7	IRB 1200-5/0.9	IRB 1200-7/0.9
1 kg picking cycle			
25 x 300 x 25 mm	0.4s	0.41s	0.41s
Max. TCP Acceleration	35 m/s*s	36 m/s*s	36m/s*s
Acceleration time 0-1 m/s	0.06 s	0.06 s	0.06 s
Position repeatability	0.02 mm	0.025 mm	0.013 mm

¹ based on OmniCore E10

Technical information

Electrical Connections

Supply voltage	200-600 V, 50-60 Hz
Rated power transformer rating	4.5 kVA
Power consumption	0.39 kW

Physical

Robot base	210 x 210 mm
Robot height	
IRB 1200-7/0.7	869 mm
IRB 1200-5/0.9	967 mm
IRB 1200-7/0.9	967 mm
Robot weight	
IRB 1200-7/0.7	52 kg
IRB 1200-5/0.9	54 kg
IRB 1200-7/0.9	54 kg

Environment

Ambient temperature for robot manipulator	
During operation	+ 5°C (41°F) to + 45°C (113°F)
With food grade lubrication during operation	+ 5°C (41°F) to + 35°C (95°F)
Complete robot during transportation and storage	- 25°C (-13°F) to + 55°C (131°F)
During short periods (max. 24 hours)	up to + 70°C (158°F)
Relative humidity	Max. 95%
Noise level	< 70 dB

Data and dimensions may be changed without notice.

We reserve the right to make technical changes or modify the contents of this document without prior notice. With regard to purchase orders, the agreed particulars shall prevail. ABB does not accept any responsibility whatsoever for potential errors or possible lack of information in this document.

Movement

Axis movement	Working range	Axis max. speed
Axis 1 rotation	+170° to -170°	288°/s
Axis 2 arm	+135° to -100° ²	240°/s
Axis 3 arm	+70° to -200°	297°/s
Axis 4 wrist	+270° to -270°	400°/s
Axis 5 bend	+130° to -130°	405°/s
Axis 6 turn	Default: +400° to -400° Max. rev: ±242	600°/s

²Axis 2 for IRB1200-5/0.9 and IRB1200-7/0.9 is +130° to -100°

* IRB1200-7/0.9 Wall mounted robot has a work area for axis 1 that depends on payload and the positions of other axes. Simulation in RobotStudio is recommended

Working range, IRB 1200 7/0.7

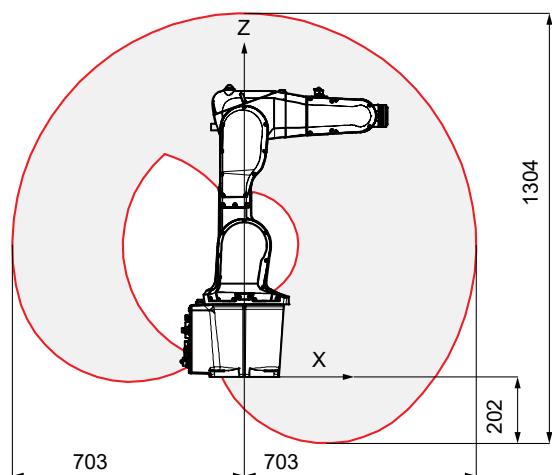

Working range, IRB 1200 5/0.9 and IRB 1200-7/0.9

